

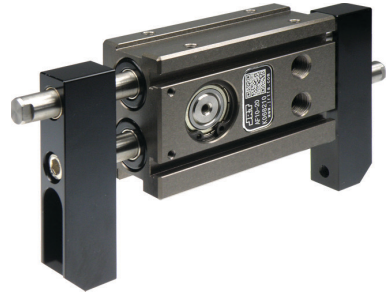

## 특징 (Character)

- RACK & PINION에 의한 광폭형 개폐방식  
Rack & pinion type
- SLIM TYPE BODY의 횡형 개폐방식으로 광범위한 제품파지에 적합한 구조  
Suitable structure for extensive gripping work by slim type body`s horizontal opening type
- 개폐검출 센서 전기종 부착가능  
Magnetic sensor is available for open-close sensing
  - ▶ AF10 TYPE은 닫힐때 가이드 로드가 돌출됩니다.
  - ▶ Guide rod protrudes when AF10 type is closed



## 랙 & 피니언 방식 (Rack & Pinion type)

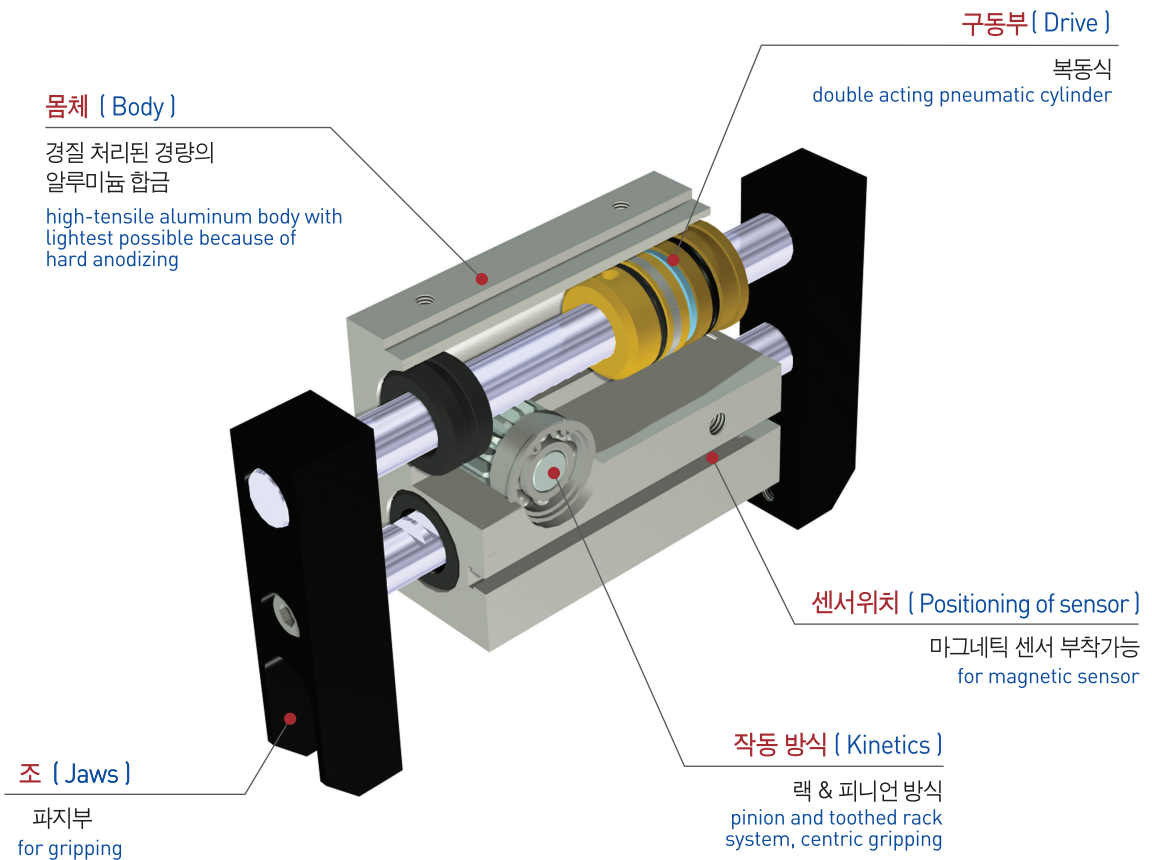

부품분해도 ( Exploded view )

※ 본 분해도는 한 제품을 예시하였으므로 기종별로 차이가 있을 수 있습니다  
 ※ This exploded view illustrates a certain product only. The contents may vary by product models.

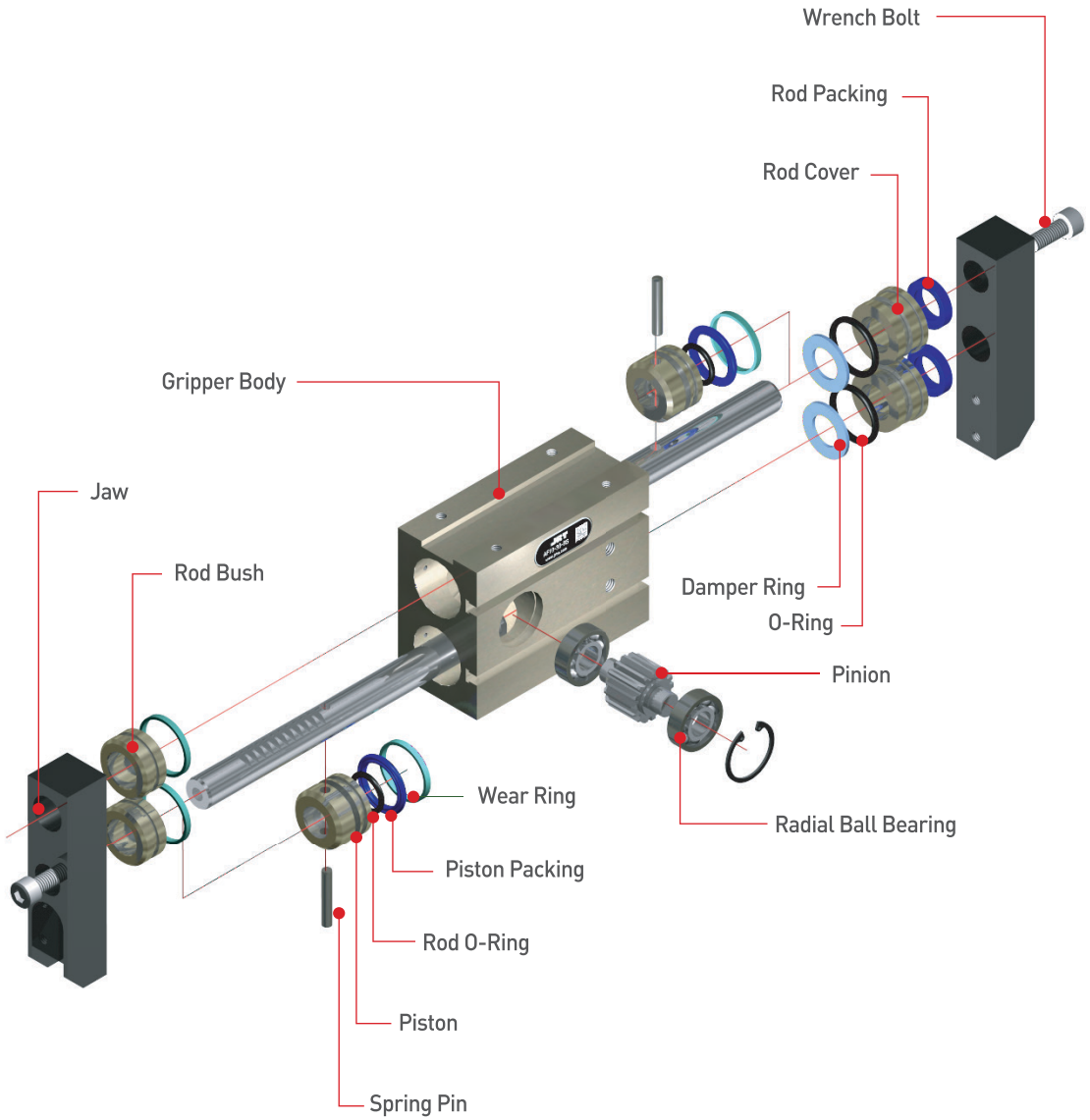

AF101
AF02
AF03
AF04P
AF105P
AF06
<b>AF10</b>
AF13
AF13C
AF14
AF15
AF316
AF17
AF117
AF19
AF24
AF26
AF28D
AF30
AF30L
AF30SP
AF40
AF46
AF56N
RAF56N
MF16

주문기호 ( Ordering Code )

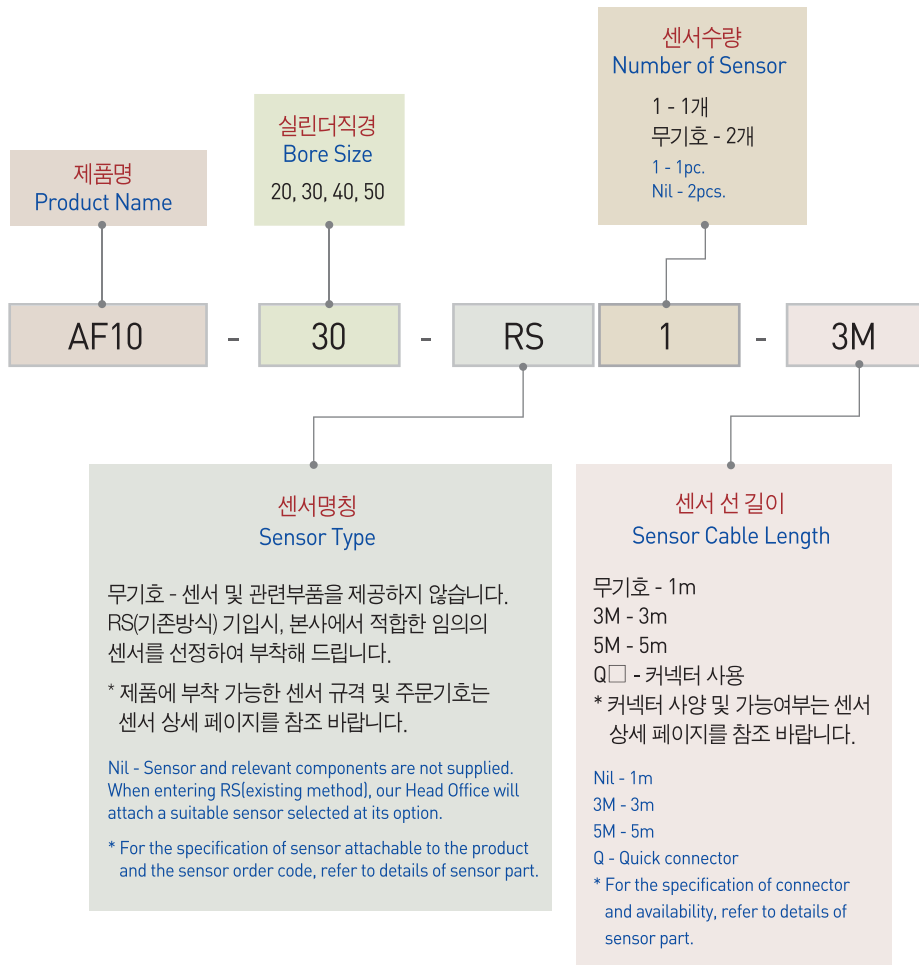
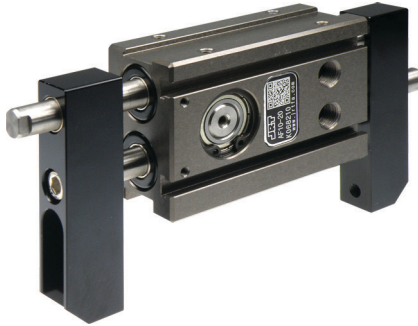

## ☐ 제품사양 ( Specification )

P=공기압력(bar) , L=작용점까지의 거리(mm)  
P=Air Pressure(bar) , L=Exertion length(mm)

제품명칭 Products Name	AF10-20	AF10-30	AF10-40	AF10-50	단위 Unit
개폐범위 Stroke	30	40	60	100	mm
제품중량 Weight	0.67	1.96	4.6	9.22	kg
최대치구길이 Max. length attach	60	85	120	160	mm
배관접속구 Fitting size	PF(G) 1/8	PF(G) 1/8	PF(G) 1/8	PF(G) 1/8	
파지력 : 열림시 Gripping force : Open	11.48P/(1+0.015L)	25.02P/(1+0.015L)	41.2P/(1+0.015L)	63.77P/(1+0.015L)	N
파지력 : 닫힘시 Gripping force : Close	11.48P/(1+0.015L)	25.02P/(1+0.015L)	41.2P/(1+0.015L)	63.77P/(1+0.015L)	N
1사이클당 공기소모량 Air consumption per cycle	8.2	24.3	66.0	171.8	cm <sup>3</sup>
닫힘시/열림시 시간 Closing / Opening time	0.01/0.01	0.01/0.01	0.03/0.03	0.09/0.09	sec
반복정밀도 Repeat accuracy	0.1				mm
연속사용회수 Continuation usage amount	60				cpm
사용압력 Operating pressure	3~7				bar
주위온도 Ambient temperature	-5 to 60				℃
윤활 Lubrication	불필요 Needless				

반복정밀도 : 연속 100회 작동후 측정치  
After 100 consecutive strokes to end positions

## ☐ 작용점에서의 파지력 ( Gripping Force From a Point of Action )

범례( Legend ) : —■ 7[bar] —■ 5[bar] —■ 3[bar]

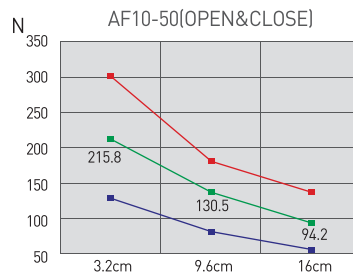
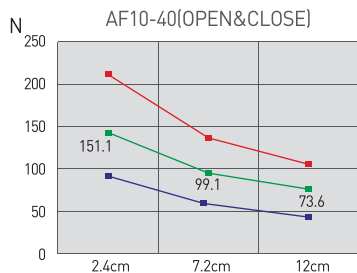
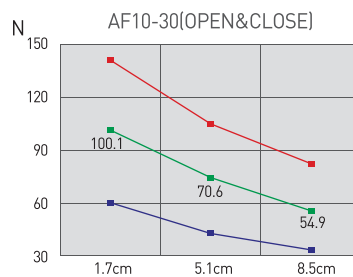
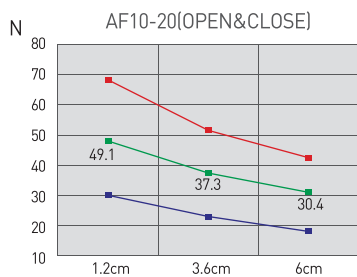

- AF101
- AF02
- AF03
- AF04P
- AF105P
- AF06
- AF10**
- AF13
- AF13C
- AF14
- AF15
- AF316
- AF17
- AF117
- AF19
- AF24
- AF26
- AF28D
- AF30
- AF30L
- AF30SP
- AF40
- AF46
- AF56N
- RAF56N
- MF16

AF10-20

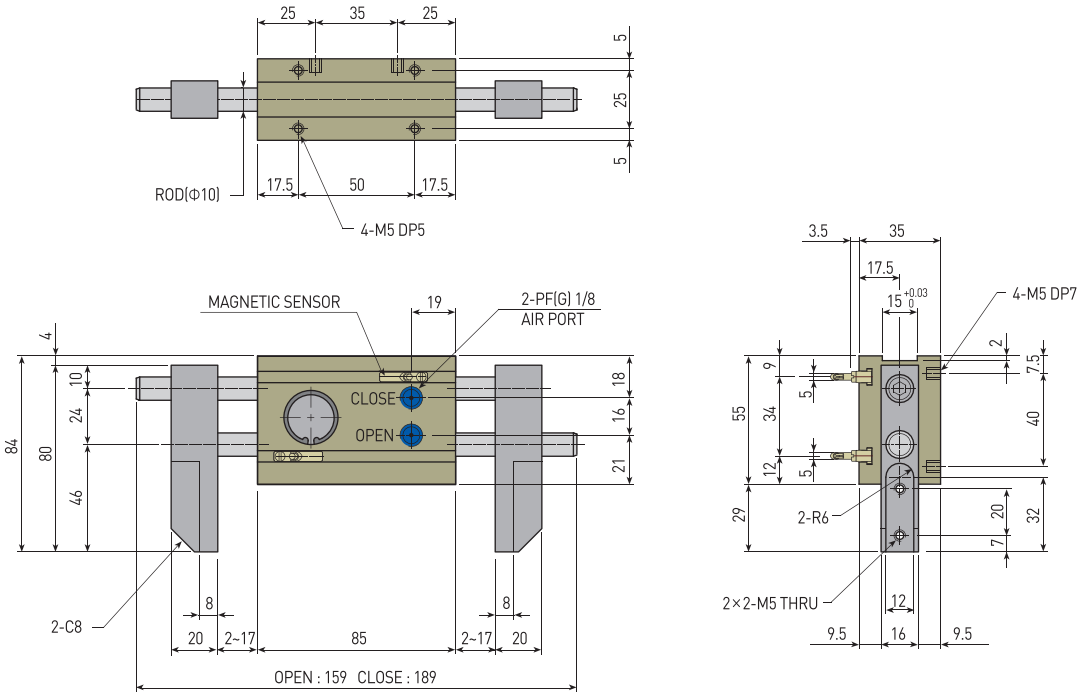

AF10-30

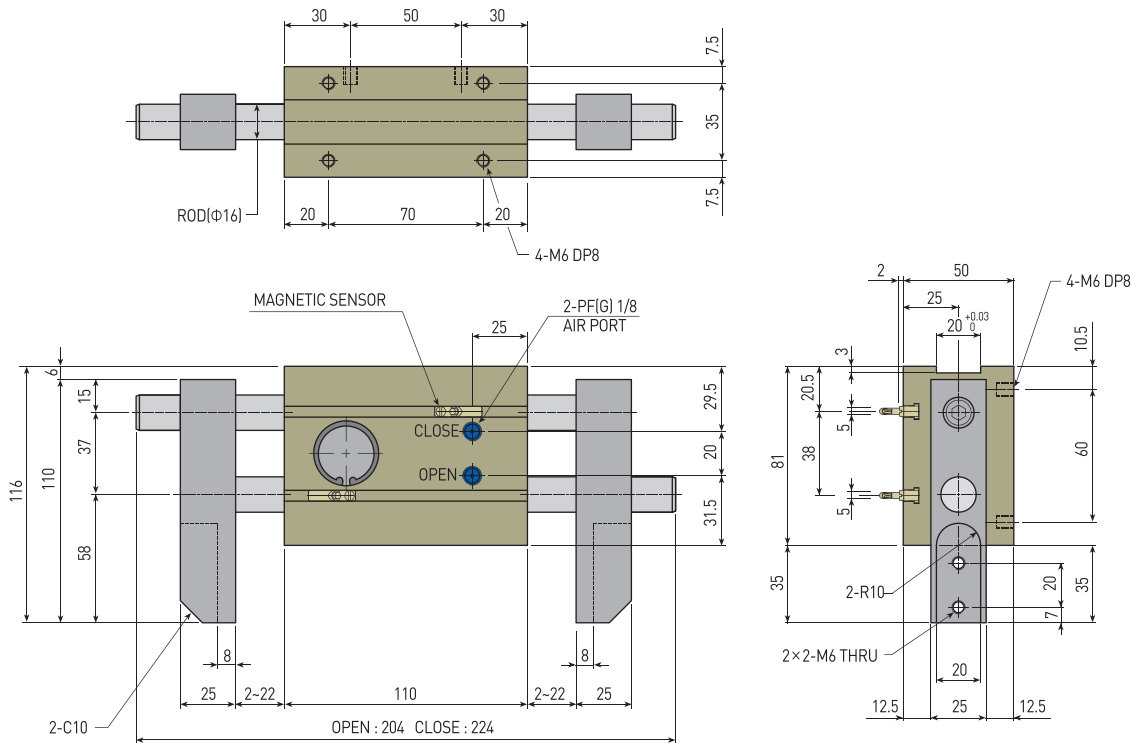

AF10-40

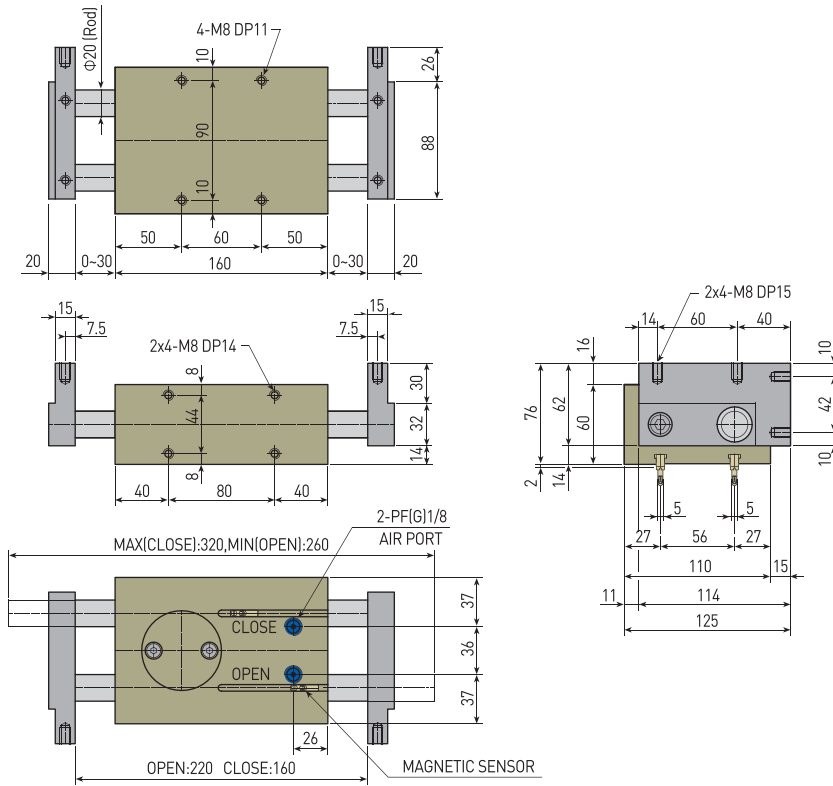

AF10-50

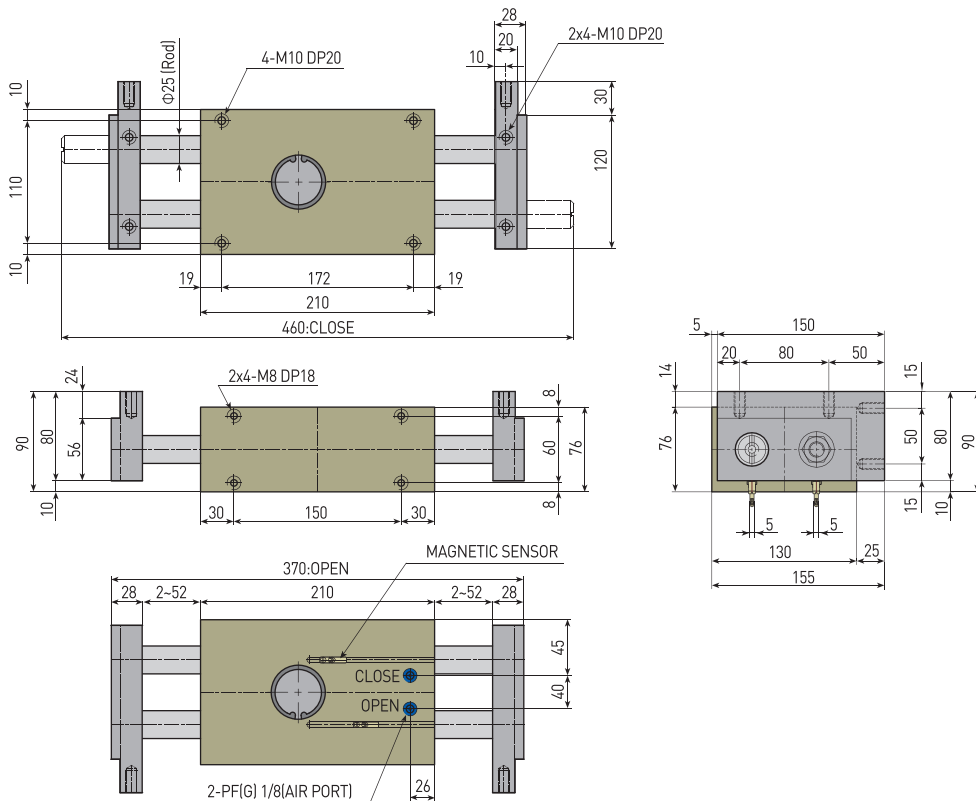

- AF101
- AF02
- AF03
- AF04P
- AF105P
- AF06
- AF10**
- AF13
- AF13C
- AF14
- AF15
- AF316
- AF17
- AF117
- AF19
- AF24
- AF26
- AF28D
- AF30
- AF30L
- AF30SP
- AF40
- AF46
- AF56N
- RAF56N
- MF16